

OPÉRA-COMIQUE en 3 Actes

# LA FILLEULE DU ROI

Musique de A. VOGEL



Quadrille pour PIANO par

# ARBAN

PARIS  
ENOCH PÈRE & FILS  
27, Boulev. des Italiens.

LONDON  
ENOCH & SONS  
19, Holles Street.

Limp. Frouy, Paris.

à 2 Mains 5f  
à 4 Mains 6f

*Handwritten notes:*  
 A. Henio de 1875  
 Bernareggi  
 Madrid 23/4/1  
 96/97

# LA FILLEULE DU ROI

## QUADRILLE.

OPÉRA - COMIQUE EN 3 ACTES DE A. VOGEL.



Par ARBAN.

N<sup>o</sup> 1.

CHŒUR DES CUISINIERS.

PANTALON.

CODA.

FIN. DUO. «Où, j'ai lu dans ton cœur»

D.C.

DUO. «Voici l'instant ma fille»

NO 2.  
ÉTÉ.

*f*

This musical score is for a piano duo in 2/4 time, marked 'NO 2.' and 'ÉTÉ.'. The key signature has one sharp (F#). The piece begins with a forte (*f*) dynamic. The right hand features a melodic line with eighth-note patterns and some grace notes. The left hand provides a rhythmic accompaniment with chords and eighth-note figures. The score consists of 12 measures.

COUPLETS. «Ne me parlez pas des gens qui font de l'embarras»

*mf* *sf* *p*

This musical score is for piano couplets in 2/4 time, marked 'COUPLETS. «Ne me parlez pas des gens qui font de l'embarras»'. The key signature has one sharp (F#). The piece starts with a mezzo-forte (*mf*) dynamic, followed by a sforzando (*sf*) dynamic, and then a piano (*p*) dynamic. The right hand has a melodic line with eighth notes and some rests. The left hand has a steady accompaniment of chords and eighth notes. The score consists of 12 measures.

*mf* *sf* *f* *f*

This musical score continues the couplets from the previous system. It starts with a mezzo-forte (*mf*) dynamic, followed by a sforzando (*sf*) dynamic, and then two measures of forte (*f*) dynamics. The right hand continues with a melodic line, and the left hand provides accompaniment. The score ends with a double bar line and a repeat sign. The score consists of 12 measures.

D.C.

RONDE. «La Jeanneton pour dot n'aura dit-on»

N<sup>o</sup> 3.

POULE.

The first system of the 'POULE' section consists of two staves. The treble staff begins with a treble clef, a key signature of one flat (B-flat), and a 6/8 time signature. The music starts with a forte (*f*) dynamic. The bass staff begins with a bass clef, the same key signature, and a 6/8 time signature. The music is primarily composed of chords and rhythmic patterns.

The second system of the 'POULE' section consists of two staves. The treble staff continues with a treble clef, one flat, and 6/8 time. The music starts with a piano (*p*) dynamic. The bass staff continues with a bass clef, one flat, and 6/8 time. The music features more melodic lines in the treble and rhythmic accompaniment in the bass.

CODA.

The CODA section consists of two staves. The treble staff begins with a treble clef, one flat, and 6/8 time. The music starts with a forte (*f*) dynamic. The bass staff begins with a bass clef, one flat, and 6/8 time. The music is primarily composed of chords and rhythmic patterns.

FIN. DUO. «Elle avait même une servante»

The DUO section consists of two staves. The treble staff begins with a treble clef, one flat, and 6/8 time. The music starts with a forte (*f*) dynamic. The bass staff begins with a bass clef, one flat, and 6/8 time. The music features more melodic lines in the treble and rhythmic accompaniment in the bass. The section ends with a double bar line and a final chord.

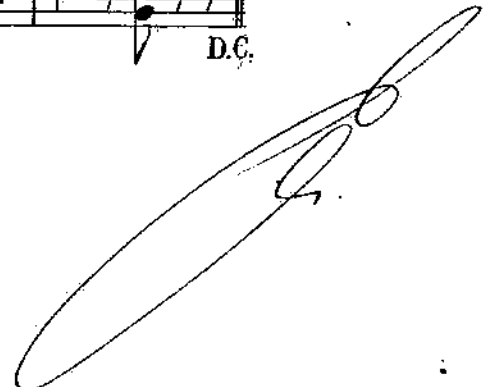

№ 4.

PASTOURELLE.

« Ehl zon, zin, zin, musettes »

The first system of music is for 'Pastourelle'. It consists of two staves, treble and bass clef, with a key signature of one sharp (F#) and a 2/4 time signature. The music begins with a forte (*f*) dynamic. The melody in the treble clef features eighth and sixteenth notes, with some grace notes and accents. The bass clef provides a steady accompaniment of eighth notes.

DANSES DU 4<sup>or</sup> ACTE.  
*brillante.*

The second system of music is for 'Dances du 4<sup>or</sup> Acte'. It consists of two staves, treble and bass clef, with a key signature of one sharp (F#) and a 2/4 time signature. The music begins with a mezzo-forte (*mf*) dynamic. The melody in the treble clef is highly rhythmic, featuring many sixteenth notes and trills (*tr*). The bass clef provides a steady accompaniment of eighth notes.

The third system of music continues the 'Dances du 4<sup>or</sup> Acte'. It consists of two staves, treble and bass clef, with a key signature of one sharp (F#) and a 2/4 time signature. The melody in the treble clef continues with sixteenth notes and trills (*tr*). The bass clef provides a steady accompaniment of eighth notes.

The fourth system of music is the final system of 'Dances du 4<sup>or</sup> Acte'. It consists of two staves, treble and bass clef, with a key signature of one sharp (F#) and a 2/4 time signature. The music concludes with a forte (*f*) dynamic and a double bar line. The treble clef melody features sixteenth notes and trills (*tr*). The bass clef provides a steady accompaniment of eighth notes. The piece ends with a double bar line and the marking 'D.C.' (Da Capo).

Leggiero. FINAL DU 1<sup>er</sup> ACTE.

№ 5.

FINAL.

Musical notation for the first system, featuring a treble and bass staff. The treble staff begins with a piano (*p*) dynamic and a crescendo marking. The bass staff provides harmonic support with chords and moving lines.

1<sup>re</sup> et 3<sup>e</sup> Fois.

Musical notation for the second system, featuring a treble and bass staff. The treble staff has a fortissimo (*ff*) dynamic marking. The bass staff continues with harmonic accompaniment.

Musical notation for the third system, featuring a treble and bass staff. The treble staff includes various dynamics and articulation marks such as accents and slurs.

CHANSON DE LA GARBURE.

2<sup>e</sup> et 4<sup>e</sup> Fois.

Musical notation for the fourth system, featuring a treble and bass staff. The treble staff has piano (*p*) and forte (*f*) markings. A *D.C.* instruction is present below the bass staff.

Musical notation for the fifth system, featuring a treble and bass staff. The treble staff has a piano (*p*) marking. A *D.C.* instruction is present at the end of the system.



D.C.